

FITZROY BALL BEARING DOOR TRACKS

ALLOY LIGHT A100p ALLOY MEDIUM A500p

Fig. 2

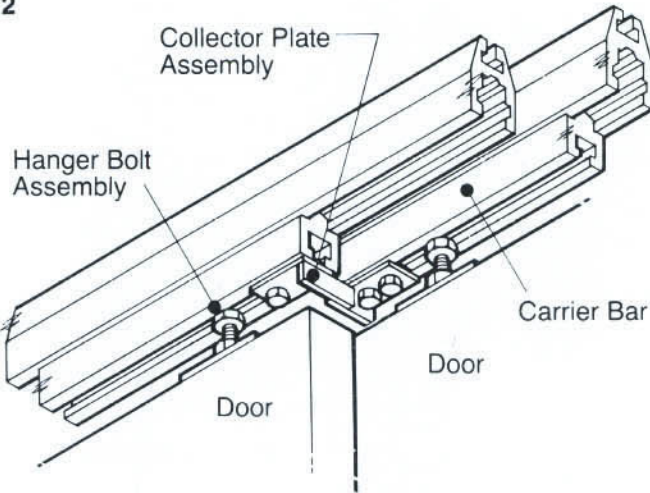

Shown on this page is a Parallel Door System using the Alloy Light "Fitzroy" Door Track.

Fig. 1: a plan of a three door arrangement rotating the various dimensional requirements. The circled views detail the door location arrangements at floor level.

Fig. 2: a detail of the door hanging arrangement and the door collector assembly. The collector plates control the location of each door and allow them to be opened or closed in sequence.

The assembly weight should not exceed 100 kgs per door for Alloy Light A100p and 500 kgs for Alloy Medium A500p.

Fig. 1

